



TECHNICAL DATA

EC/QREC ORDINARY HAZARD PENDENT SPRINKLER VK572 (K14.0)

The Viking Corporation, 210 N Industrial Park Drive, Hastings MI 49058

Telephone: 269-945-9501 Technical Services: 877-384-5464 Fax: 269-818-1680 Email: techsvcs@vikingcorp.com

Visit the Viking website for the latest edition of this technical data page www.vikinggroupinc.com

1. DESCRIPTION

Viking Standard/Quick Response Extended Coverage Ordinary Hazard (ECOH) Pendent Sprinkler VK572 is a thermosensitive glass bulb spray sprinkler with a 14.0 (202 metric*) nominal K-Factor. The sprinkler produces the flows required to meet Ordinary Hazard density requirements at lower pressures than 8.0 or 11.2 (115.2 or 161.4 metric*) K-Factor sprinklers. The glass bulb operating element and special deflector characteristics meet the challenges of quick response extended coverage standards. Viking EC/QREC Ordinary Hazard Sprinklers are available in various finishes and temperature ratings to meet design requirements. The special Polyester coatings can be used in decorative applications where colors are desired. In addition, the ENT coating has been investigated for installation in corrosive environments and is listed as indicated in the Approval Charts. The Viking VK572 Sprinkler may be ordered and/or used as an open sprinkler (glass bulb and pip-cap assembly removed) on deluge systems. Refer to Ordering Instructions on the next page.

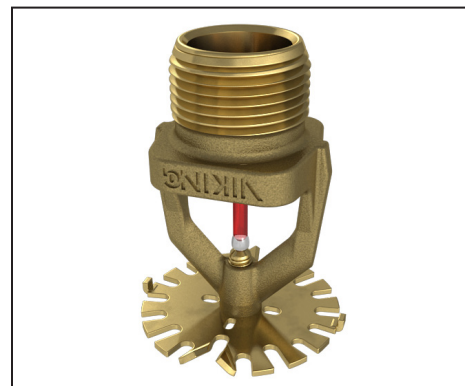

NOTE: As of May 2018 all logos have been removed from the wrench boss.

2. LISTINGS AND APPROVALS



cULus Listed: Category VNIV



FM Approved: Class 2022

NYC Approved: MEA 89-92-E, Volume 38

Refer to Approval Chart 1 and Design Criteria for cULus Listing requirements and refer to Approval Chart 2 and Design Criteria for FM Approval requirements that must be followed.



WARNING: Cancer and Reproductive Harm-
www.P65Warnings.ca.gov

3. TECHNICAL DATA

Specifications:

Available since 2004.

Minimum Operating Pressure: Refer to the Approval Charts.

Maximum Working Pressure: 175 psi (12 bar). Factory tested hydrostatically to 500 psi (34.5 bar).

Thread size: 3/4" (20 mm) NPT

Nominal K-Factor: 14.0 U.S. (202 metric*)

* Metric K-factor measurement shown is in Bar. When pressure is measured in kPa, divide the metric K-factor shown by 10.0.

Glass-bulb fluid temperature rated to -65 °F (-55 °C)

Overall Length: 2-7/16" (62 mm)

Material Standards:

Sprinkler Frame: Brass UNS-C84400

Deflector: Phosphor Bronze UNS-C51000

Bulb: Glass, nominal 3 mm diameter

Pip Cap: Brass UNS-C31400 or UNS-C31600

Compression Screw: Brass UNS-C36000

Belleville Spring Sealing Assembly: Nickel Alloy, coated on both sides with PTFE Tape

For ENT coated Sprinklers: Belleville Spring - Exposed, Screw and Pipcap - ENT plated.

For Polyester Coated Sprinklers: Belleville Spring-Exposed

Ordering Information: (Also refer to the current Viking price list.)

Order EC/QREC Ordinary Hazard Pendent Sprinkler VK572 by first adding the appropriate suffix for the sprinkler finish and then the appropriate suffix for the temperature rating to the sprinkler base part number.

Finish Suffix: Brass = A, Chrome = F, White Polyester = M-/W, Black Polyester = M-/B, and ENT = JN

Temperature Suffix (°F/°C): 155°/68° = B, 175°/79° = D, 200°/93° = E, and 286°/141° = G, OPEN = Z (PTFE only).

For example, sprinkler VK572 with a Brass finish and a 155 °F/68 °C temperature rating = Part No. 13722AB.

Available Finishes And Temperature Ratings: Refer to Table 1.



TECHNICAL DATA

**EC/QREC ORDINARY
HAZARD PENDENT
SPRINKLER VK572 (K14.0)**

The Viking Corporation, 210 N Industrial Park Drive, Hastings MI 49058

Telephone: 269-945-9501 Technical Services: 877-384-5464 Fax: 269-818-1680 Email: techsvcs@vikingcorp.com

Visit the Viking website for the latest edition of this technical data page www.vikinggroupinc.com

Accessories: (Also refer to the Viking website.)

Sprinkler Wrenches:

- A. Standard Wrench: Part No. 07297W/B (available since 1991)
 - B. Wrench for coated and/or recessed pendent sprinkler: Part No. 13032W/B** (available since 2004)
- **A 1/2" ratchet is required (not available from Viking).

Sprinkler Cabinets:

- A. Six-head capacity: Part No. 01724A (available since 1971)
- B. Twelve-head capacity: Part No. 01725A (available since 1971)

4. INSTALLATION

Refer to appropriate NFPA Installation Standards.

5. OPERATION

During fire conditions, when the temperature around the sprinkler reaches its operating temperature, the heat-sensitive liquid in the glass bulb expands, causing the bulb to shatter, releasing the pip cap and sealing spring assembly. Water flowing through the sprinkler orifice strikes the sprinkler deflector, forming a uniform spray pattern to extinguish or control the fire.

6. INSPECTIONS, TESTS AND MAINTENANCE

Refer to NFPA 25 for Inspection, Testing and Maintenance requirements

7. AVAILABILITY

The Viking Model VK572 Sprinkler is available through a network of domestic and international distributors. See The Viking Corporation web site for the closest distributor or contact The Viking Corporation.

8. GUARANTEE

For details of warranty, refer to Viking's current list price schedule or contact Viking directly.

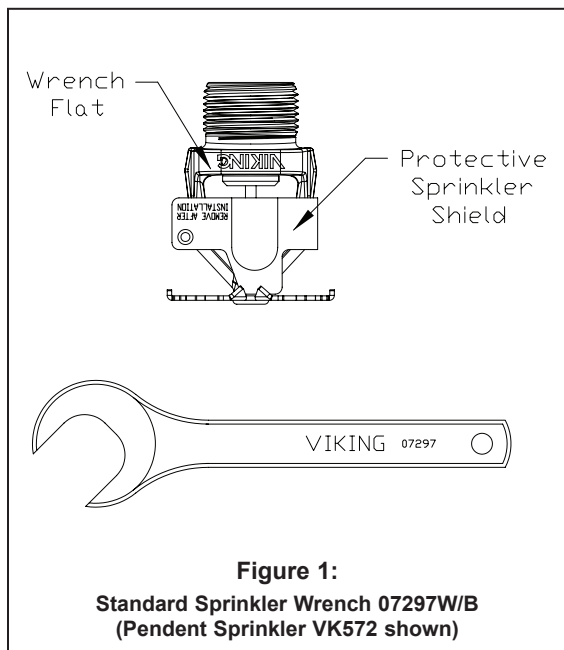

Figure 1:
Standard Sprinkler Wrench 07297W/B
(Pendent Sprinkler VK572 shown)

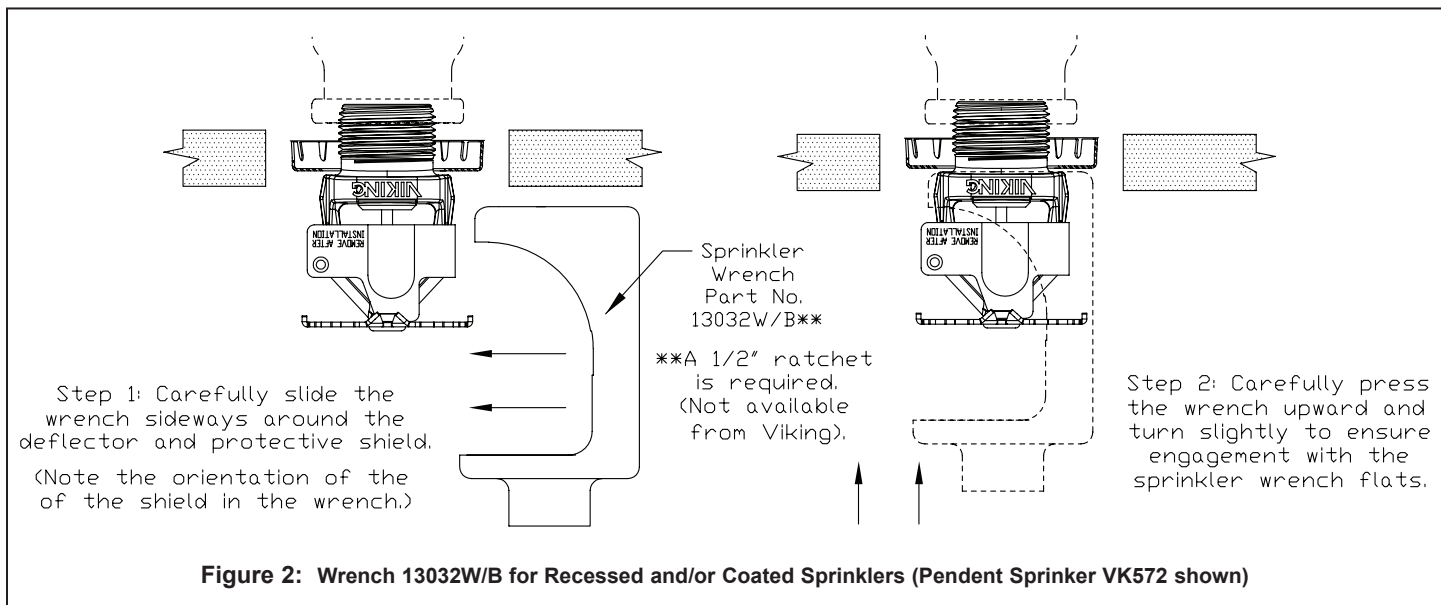

Figure 2: Wrench 13032W/B for Recessed and/or Coated Sprinklers (Pendent Sprinkler VK572 shown)



TECHNICAL DATA

EC/QREC ORDINARY
HAZARD PENDENT
SPRINKLER VK572 (K14.0)

The Viking Corporation, 210 N Industrial Park Drive, Hastings MI 49058
 Telephone: 269-945-9501 Technical Services: 877-384-5464 Fax: 269-818-1680 Email: techsvcs@vikingcorp.com
 Visit the Viking website for the latest edition of this technical data page www.vikinggroupinc.com

TABLE 1: AVAILABLE SPRINKLER TEMPERATURE RATINGS AND FINISHES

Sprinkler Temperature Classification	Sprinkler Nominal Temperature Rating ¹	Maximum Ambient Ceiling Temperature ²	Bulb Color
Ordinary	155 °F (68 °C)	100 °F (38 °C)	Red
Intermediate	175 °F (79 °C)	150 °F (65 °C)	Yellow
Intermediate	200 °F (93 °C)	150 °F (65 °C)	Green
High	286 °F (141 °C)	225 °F (107 °C)	Blue

Available Sprinkler Finishes: Brass, Chrome, White Polyester³, Black Polyester³, and ENT³

Corrosion Resistant/Proofing Sprinkler Finishes: ENT³

Footnotes

- ¹ The sprinkler temperature rating is stamped on the deflector.
- ² Based on NFPA-13. Other limits may apply, depending on fire loading, sprinkler location, and other requirements of the Authority Having Jurisdiction. Refer to specific installation standards.
- ³ The corrosion-resistant coatings have passed the standard corrosion test required by the approving agencies indicated in the Approval Charts. These tests cannot and do not represent all possible corrosive environments. Prior to installation, verify through the end-user that the coatings are compatible with or suitable for the proposed environment. For automatic sprinklers, the coatings indicated are applied to the exposed exterior surfaces only. Note that the spring is exposed on sprinklers with Polyester and ENT. For ENT coated automatic sprinklers, the waterway is coated.

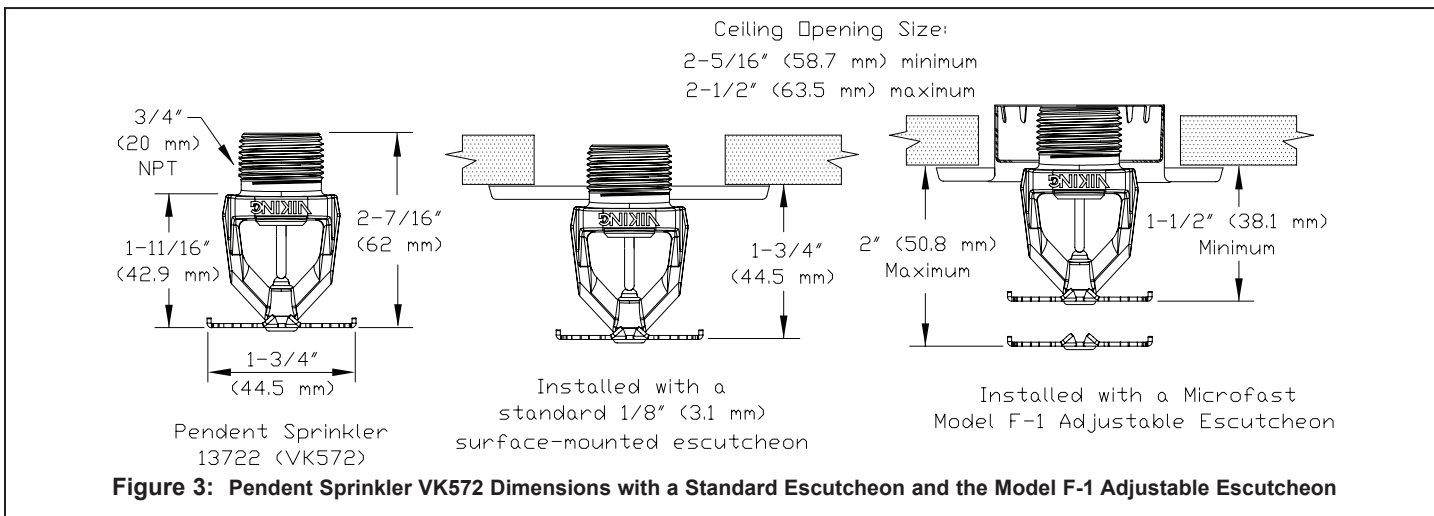



TECHNICAL DATA

**EC/QREC ORDINARY
HAZARD PENDENT
SPRINKLER VK572 (K14.0)**

The Viking Corporation, 210 N Industrial Park Drive, Hastings MI 49058
 Telephone: 269-945-9501 Technical Services: 877-384-5464 Fax: 269-818-1680 Email: techsvcs@vikingcorp.com
 Visit the Viking website for the latest edition of this technical data page www.vikinggroupinc.com

Approval Chart 1 (UL)

Standard/Quick Response Extended Coverage
 Ordinary Hazard Pendent Sprinkler VK572 (K14.0)

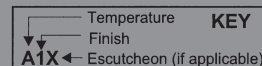

Sprinkler Base Part Number ¹	SIN	NPT Thread Size		Nominal K-Factor		Maximum Water Working Pressure	Overall Length	
		Inches	mm	U.S.	metric ²		Inches	mm
13722 Pendent	VK572	3/4	20	14.0	202	175 psi (12 bar)	2-7/16	62
Maximum Sprinkler Spacing L x W ⁵	Maximum Area per Sprinkler	Minimum Water Supply Requirements (cULus only)				cULus/NYC Listings ^{3,4,7} (See Design Criteria)		
		Ordinary Hazard Group I		Ordinary Hazard Group II				
		Flow / Pressure		Flow / Pressure				
Standard Response						Pendent VK572		
16 ft. x 16 ft. (4.9 m x 4.9 m)	256 ft ² (23.8 m ²)	39 gpm @ 7.8 psi (147.6 l/min @ 0.54 bar)		51 gpm @ 13.3 psi (193.1 l/min @ 0.92 bar)		A1X, B1Y		
18 ft. x 18 ft. (5.5 m x 5.5 m)	324 ft ² (30.1 m ²)	49 gpm @ 12.3 psi (185.5 l/min @ 0.85 bar)		65 gpm @ 21.6 psi (246.1 l/min @ 1.49 bar)		A1X, B1Y		
20 ft. x 20 ft. (6.1 m x 6.1 m)	400 ft ² (37.2 m ²)	60 gpm @ 18.4 psi (227.1 l/min @ 1.27 bar)		80 gpm @ 32.7 psi (302.8 l/min @ 2.25 bar)		A1X, B1Y		
Quick Response ^{6,8}								
12 ft. x 12 ft. (3.7 m x 3.7 m)	144 ft ² (13.4 m ²)	39 gpm @ 7.8 psi (147.6 l/min @ 0.54 bar)		39 gpm @ 7.8 psi (147.6 l/min @ 0.54 bar)		A1X, B1Y		
14 ft. x 14 ft. (4.3 m x 4.3 m)	196 ft ² (18.2 m ²)	39 gpm @ 7.8 psi (147.6 l/min @ 0.54 bar)		39 gpm @ 7.8 psi (147.6 l/min @ 0.54 bar)		A1X, B1Y		
Approved Temperature Ratings		Approved Finishes		Approved Escutcheons				
A - 155 °F (68 °C), 175 °F (79 °C), 200 °F (93 °C), and 286 °F (141 °C) ⁶ B - 155 °F (68 °C), 175 °F (79 °C), and 200 °F (93 °C)		1 - Brass, Chrome, White Polyester, Black Polyester, and ENT ⁹		X - Standard surface-mounted escutcheons or the Microfast [®] Model F-1 Adjustable Escutcheon Y - Standard surface-mounted escutcheons or the Microfast [®] Model F-1 Adjustable Escutcheon, or recessed with the Micromatic [®] Model E-1 or E-2 Recessed Escutcheon				

Footnotes

- ¹ Part number shown is the base part number. For complete part number, refer to current Viking price list schedule.
- ² Metric K-factor measurement shown is when pressure is measured in Bar. When pressure is measured in kPa, divide the metric K-factor shown by 10.0.
- ³ This chart shows listings and approvals available at time of printing. Other approvals may be in process. Check with the manufacturer for any additional approvals.
- ⁴ cULus Listed for use in the U.S. and Canada.
- ⁵ To determine "Minimum Water Supply Requirement" for areas of coverage where length and width of actual sprinkler spacing are not equal, select the "Maximum Sprinkler Spacing" from the chart that is equal to or greater than the larger of the actual spacing (length or width) dimensions used. Example: When using 10 ft 6 in x 13 ft (3.2 m x 4 m) sprinkler spacing, provide the "Minimum Water Supply Requirement" listed in the chart for 14 ft x 14 ft (4.3 m x 4.3 m) spacing. For areas of coverage smaller than shown, use the "Minimum Water Supply Requirement" in the appropriate hazard group for the next larger area listed. The distance from sprinklers to walls shall not exceed one-half the "Maximum Sprinkler Spacing" listed for the "Minimum Water Supply Requirement" used.
- ⁶ For Sprinkler VK572 with High Temperature 286 °F rating, UL restricts the QR listing to their use in Ordinary Hazard occupancies to the high temperature zones within a building only. VK572 quick response sprinklers with this temperature rating cannot be used throughout the property.
- ⁷ Accepted for use, City of New York Department of Buildings, MEA Number 89-92-E, Vol. 38.
- ⁸ Prior to 2007, sprinkler VK572 was classified as Standard Response for all room sizes.
- ⁹ cULus Listed as corrosion resistant.



TECHNICAL DATA

EC/QREC ORDINARY HAZARD PENDENT SPRINKLER VK572 (K14.0)

The Viking Corporation, 210 N Industrial Park Drive, Hastings MI 49058

Telephone: 269-945-9501 Technical Services: 877-384-5464 Fax: 269-818-1680 Email: techsvcs@vikingcorp.com

Visit the Viking website for the latest edition of this technical data page www.vikinggroupinc.com

DESIGN CRITERIA - UL

(Also refer to Approval Chart 1.)

cULus Listing Requirements: ECOH Pendent Sprinkler VK572 is cULus Listed as Standard and Quick Response for installation in accordance with the latest edition of NFPA 13 for extended coverage pendent spray sprinklers as indicated below:

- The minimum water supplies and maximum areas of coverage shown in Approval Chart 1 are designed to provide the following design densities: 0.15 gpm/ft² (6.1 mm/min) for Ordinary-Hazard Group I densities; 0.2 gpm/ft.² (8.1 mm/min) for Ordinary-Hazard Group II densities.
- The sprinkler installation rules contained in NFPA 13 for extended coverage pendent spray sprinklers must be followed with the exception that cULus Listing requires the spacing between Viking ECOH Pendent Sprinklers to be a minimum of 9 ft. (2.75 m) to prevent cold soldering.
- Viking ECOH Pendent Sprinklers are cULus Listed for use in unobstructed construction, and noncombustible obstructed construction consisting of solid steel and/or concrete beams as defined in the latest edition of NFPA 13.
- Ceiling slope not to exceed 2/12 (9.5°).

Also, Viking ECOH Pendent Sprinkler VK572 is specifically cULus Listed for:

- For non-combustible obstructed construction within trusses or bar joists having non-combustible web members greater than 1" (25.4 mm) when applying the 4 times obstruction criteria rule as defined in NFPA 13 under "Obstructions to Sprinkler Discharge Pattern Development".
- For installation under concrete tees when installed as follows:
 1. The stems of the concrete tee construction must be spaced between 3 ft (0.9 m) and 7 ft-6 in (2.3 m) on center. The depth of the concrete tees must not exceed 30 in (762 mm). The maximum permitted concrete tee length is 32 ft (9.8 m). However, where the concrete tee length exceeds 32 ft (9.8 m), non-combustible baffles, equal in height to the depth of the tees, can be installed so that the space between the tees does not exceed 32 ft (9.8 m).
 2. The sprinkler deflector is to be located in a horizontal plane at or above 1" (25.4 mm) below the bottom of the concrete tee stems.

IMPORTANT: Always refer to Bulletin Form No. F_091699 - Care and Handling of Sprinklers. Also refer to Form No. 080614 for general care, installation, and maintenance information. Viking sprinklers are to be installed in accordance with the latest edition of Viking technical data, the appropriate standards of NFPA, FM Global, LPCB, APSAD, VdS or other similar organizations, and also with the provisions of governmental codes, ordinances, and standards, whenever applicable.



TECHNICAL DATA

EC/QREC ORDINARY HAZARD PENDENT SPRINKLER VK572 (K14.0)

The Viking Corporation, 210 N Industrial Park Drive, Hastings MI 49058

Telephone: 269-945-9501 Technical Services: 877-384-5464 Fax: 269-818-1680 Email: techsvcs@vikingcorp.com

Visit the Viking website for the latest edition of this technical data page www.vikinggroupinc.com

Approval Chart 2 (FM)

Quick Response Extended Coverage Pendent Sprinkler VK572 (K14.0)
For HC-1, HC-2, and HC-3 Occupancies

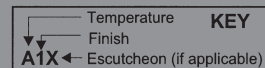

Sprinkler Base Part Number ¹	SIN	NPT Thread Size		Nominal K-Factor		Maximum Water Working Pressure	Overall Length	
		Inches	mm	U.S.	metric ²		Inches	mm
13722	VK572	3/4	20	14.0	202	175 psi (12 bar)	2-7/16	62
Maximum Sprinkler Spacing L x W ⁴		Maximum Area per Sprinkler		Refer to Design Criteria below. NOTE: FM installation guidelines may differ from cULus and/or NFPA criteria. Refer to the latest applicable FM Loss Prevention Data Sheets (including 2-0 and 3-26).			FM Approvals ³ Pendent Sprinkler VK572	
12 ft. x 12 ft. (3.7 m x 3.7 m)		144 ft ² (13.4 m ²)					A1X	
14 ft. x 14 ft. (4.3 m x 4.3 m)		196 ft ² (18.2 m ²)					A1X	
16 ft. x 16 ft. (4.9 m x 4.9 m)		256 ft ² (23.8 m ²)					A1X	
18 ft. x 18 ft. (5.5 m x 5.5 m)		324 ft ² (30.1 m ²)					A1X	
20 ft. x 20 ft. (6.1 m x 6.1 m)		400 ft ² (37.2 m ²)					A1X	
Approved Temperature Ratings				Approved Finish		Approved Escutcheons		
A - 155 °F (68 °C), 175 °F (79 °C), 200 °F (93 °C), and 286 °F (141 °C) ⁶				1 - Brass		X - Standard surface-mounted escutcheons		

Footnotes

- Part number shown is the base part number. For complete part number, refer to current Viking price list schedule.
- Metric K-factor measurement shown is when pressure is measured in Bar. When pressure is measured in kPa, divide the metric K-factor shown by 10.0.
- This chart shows the FM Approvals available at time of printing. Other approvals may be in process. Check with the manufacturer for any additional approvals.
- To determine "Minimum Water Supply Requirement" for areas of coverage where length and width of actual sprinkler spacing are not equal, select the "Maximum Sprinkler Spacing" from the chart that is equal to or greater than the larger of the actual spacing (length or width) dimensions used. Example: When using 10 ft 6 in x 13 ft (3.2 m x 4 m) sprinkler spacing, provide the "Minimum Water Supply Requirement" listed in the chart for 14 ft x 14 ft (4.3 m x 4.3 m) spacing. For areas of coverage smaller than shown, use the "Minimum Water Supply Requirement" in the appropriate hazard group for the next larger area listed. The distance from sprinklers to walls shall not exceed one-half the "Maximum Sprinkler Spacing" listed for the "Minimum Water Supply Requirement" used.

DESIGN CRITERIA - FM

(Also refer to Approval Chart 2 above.)

FM Approval Requirements:

Sprinkler VK572 is FM Approved as a quick response **Non-Storage** extended coverage pendent sprinkler as indicated in the FM Approval Guide for use in occupancy hazard classifications HC-1, HC-2, and HC-3. For specific application and installation requirements, reference the latest applicable FM Loss Prevention Data Sheets (including Data Sheet 2-0 and 3-26). FM Global Loss Prevention Data Sheets contain guidelines relating to, but not limited to: minimum water supply requirements, hydraulic design, ceiling slope and obstructions, minimum and maximum allowable spacing, and deflector distance below the ceiling.

NOTE: The FM installation guidelines may differ from cULus and/or NFPA criteria.

IMPORTANT: Always refer to Bulletin Form No. F_091699 - Care and Handling of Sprinklers. Also refer to Form No. 080614 for general care, installation, and maintenance information. Viking sprinklers are to be installed in accordance with the latest edition of Viking technical data, the appropriate standards of NFPA, FM Global, LPCB, APSAD, VdS or other similar organizations, and also with the provisions of governmental codes, ordinances, and standards, whenever applicable.